

ZeeWeed* pressurized ultrafiltration

model ZW1500

description and use

As a pioneer of membrane technology, SUEZ leverages decades of research, development, and operational experience in developing the most advanced pressurized ultrafiltration technology in the market, ZeeWeed 1500. ZeeWeed systems are proven to consistently outperform conventional filtration technology while meeting or exceeding regulatory requirements, regardless of source water quality.

typical applications

Versatile and reliable, the pressurized ZeeWeed 1500 is ideally suited for use in numerous applications including drinking water treatment, tertiary filtration and RO pre-treatment for brackish water and seawater. Compared to granular filter media, ZeeWeed membranes produce superior water quality and are virtually unaffected by variable raw water quality - all at a cost comparable to conventional filtration technology.

General Properties

- 0.02 μm nominal pore diameter - for optimal removal of particulates, bacteria and viruses
- PVDF hollow fiber membrane - provides high mechanical strength and chemical resistance
- Outside-in filtration - provides uniform flow distribution and high solids tolerance



Storage and Handling

Modules may be stored in the original factory packaging for up to 1 year prior to installation. Modules must be stored between 5°C and 35°C (41°F to 95°F). Do not expose the membrane module to direct sunlight (UV light).

Find a contact near you by visiting www.suezwatertechnologies.com and clicking on "Contact Us."

*Trademark of SUEZ; may be registered in one or more countries.

©2017 SUEZ. All rights reserved.

product specifications

Model	ZeeWeed 1500-600
Nominal membrane surface area	55.7 m ² (600 ft ²)
Max shipping weight¹	32 kg (70 lb)
Lifting weight²	30-36 kg (65-80 lb)
Membrane material	PVDF
Nominal pore size	0.02 micron
Nominal fiber diameter	OD: 1.1 mm, ID: 0.66 mm
Flow path	Outside-in
Housing material	PVC housing with Noryl caps

¹ Packaged

² Varies with solids accumulation

Module Dimensions		
Connections: Permeate/Feed/Reject	Height	Pipe diameter
Victaulic/Victaulic/Victaulic ³	1920 mm (75.6 in)	180 mm (7.1 in)

³ Module available with compression permeate and/or threaded reject connection(s)

operating parameters

Performance	
Flow range	45 – 180 m ³ /day (8-33 gpm)
Operating conditions	
Max shell inlet pressure	379 kPa (55 psi)
TMP range	0-276 kPa (0-40 psi)
Max temperature	40°C (104°F)
Operating pH	5.0-10.0
Max air scour flow	5.1 m ³ /h (3 dcfm)
Max backwash flow	1.8 m ³ /hr (8 gpm)
Cleaning	
Cleaning pH range	2.0-12.0
Max chlorine concentration	1,000 mg/L [as NaOCl] ⁴

⁴ NOTE: Higher concentrations are possible depending on feedwater and pH.

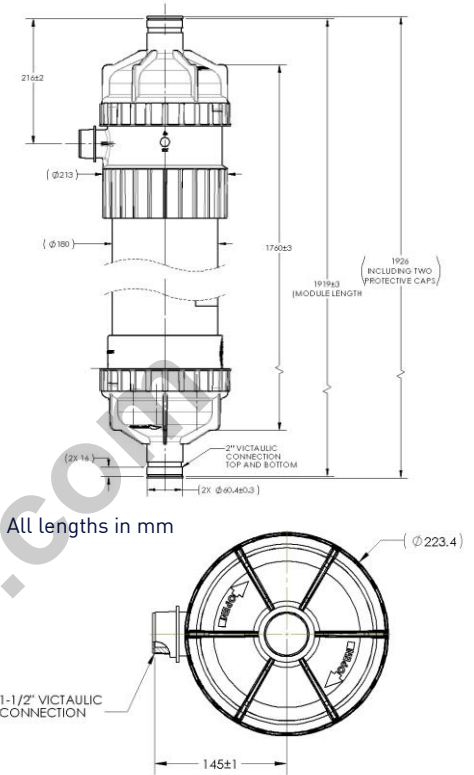

All lengths in mm

